



**PHOENIX**

METAL PRODUCTS, INC.

## Water Service Cart

**PNX - WC250**

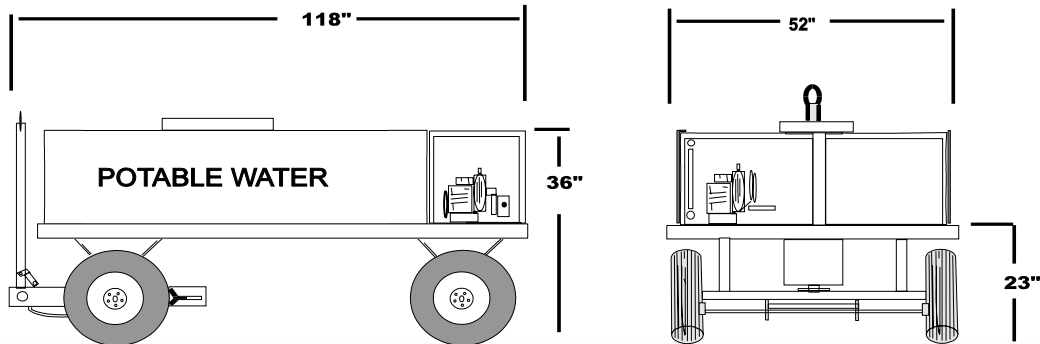

## SPECIFICATIONS

### Tank:

- \* 250 gallons

### Features:

- \* Chassis constructed of heavy gauge 3"X2" stainless steel tube
- \* Heavy gauge tubing axles galvanized
- \* Positive front wheel braking system w/latch
- \* Stainless steel top, bottom and sides
- \* Replaceable stainless bolt on sides
- \* 1 3/4" Removable spindles w/grease fittings
- \* 570 X 8" Tires and wheels
- \* Stainless steel tank
- \* Tank baffled in both directions
- \* 12" Hinged clean out on top of tank
- \* Closed fill system
- \* Insect protection
- \* 15' Food grade hose w/coupling and shutoff valve
- \* Sight gauge
- \* Water hose drain back
- \* 4hp Honda engine w/low oil shut down
- \* 1/2" Exterior grade plywood tank cushion
- \* Bronze water pump
- \* Galvanized tow bar

### Options:

- \* Full insulation top, bottom and sides
- \* Full enclosure
- \* Immersion Heater
- \* Rear work platform
- \* Corner bumpers
- \* Electric start engine
- \* Emergency hand pump

### Shipping Dimensions:

Width: 52"  
Length: 118"  
Height: 36"  
Weight: Approx. 1450 lbs.

Specification Subject to Change Due to Product Improvement

Phoenix Metal Products, Inc., 3000 Industrial Avenue, #3, Ft. Pierce, FL 34946

Phone: 772-595-6386 - Fax: 772-595-6389

Email: [phoenixgse@earthlink.net](mailto:phoenixgse@earthlink.net) URL: [www.phoenixgse.com](http://www.phoenixgse.com)