

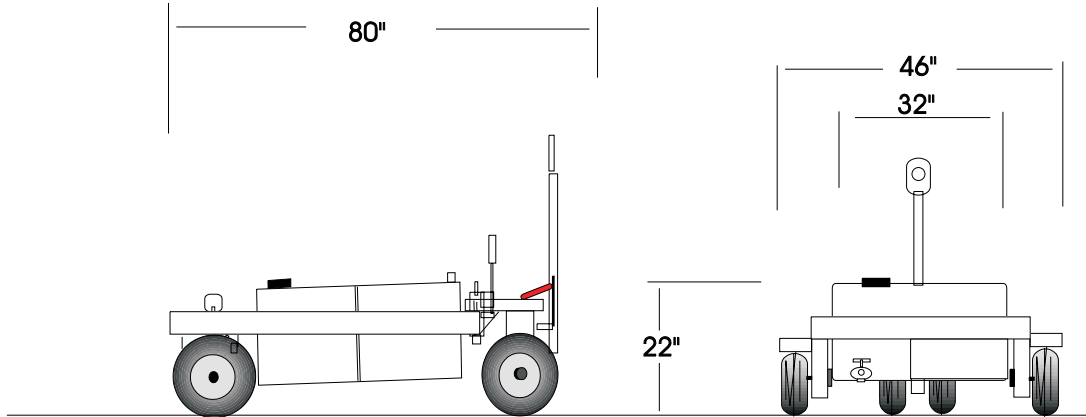

## Lavatory Service Cart

## PNX - LC50-50LP



## SPECIFICATIONS

### Tanks:

Waste: 50 Gallons  
Charge: 50 Gallons

### Features:

- \* Individual Stainless Steel Tank
- \* 3" Drain Valve
- \* 10' Drain Hose
- \* 9'4" Waste Hose w/Straight Locking Coupling
- \* 10' Charge Hose w/Roylyn Coupling
- \* Aluminum Hand Pump-5 Strokes per Gallon
- \* Charge Meter
- \* Positive Drain on Waste Tank
- \* Chassis Constructed of Structural Stainless Tubing
- \* 4 Heavy Duty Tire and Wheels w/Tapered Bearing
- \* Positive Front Brakes
- \* Removable Spindles

### Options:

- \* Two Tone Paint
- \* Electric Pump

### Shipping Dimensions:

Width: 46"  
Length: 80"  
Height: 22"  
Weight: Approx. 650 lbs.

Specification Subject to Change Due to Product Improvement

Phoenix Metal Products, Inc. 3000 Industrial Avenue, # 3, Ft Pierce, FL 34946

Phone: 772-595-6386 - Fax: 772-595-6389

Email: [phoenixgse@earthlink.net](mailto:phoenixgse@earthlink.net) URL: [www.phoenixgse.com](http://www.phoenixgse.com)